

OWNER'S MANUAL

Bull Shark 40xs

Bull Shark 50

Tiger Shark 80

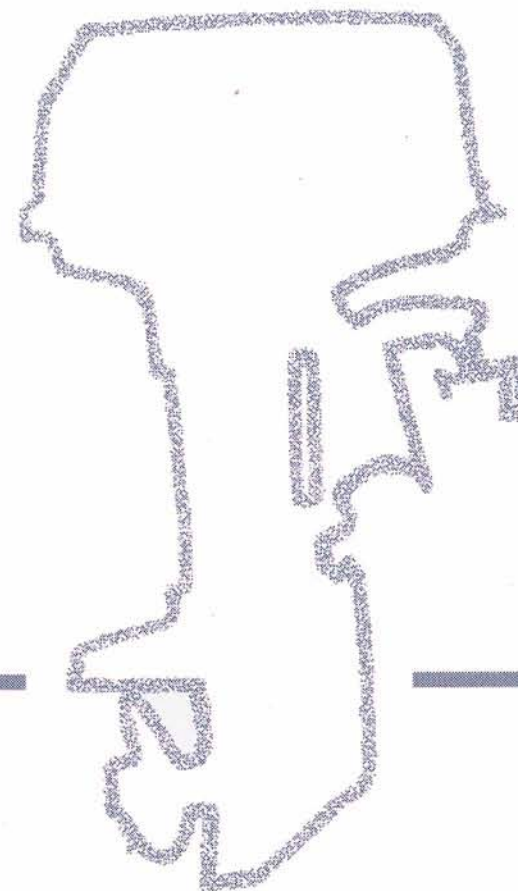

This manual must be considered as an integral part of your outboard motor and has to be kept with it, also if the motor is resold. **Selva joint-stock CO.** reserve the right to change its product at any moment, except for the essential specifications, which will be kept as they are.

Any reference to products or details of a third party has only an informative purpose and it doesn't represent an obligation.

Selva joint-stock CO. doesn't take on any responsibility concerning the performance or the employment of these products.

We are glad that you have chosen a **SELVA MARINE** product, which means quality, technology and careful research. Your choice will give you many advantages, which you will soon learn to appreciate. Our dealers, our after-sales service and the guarantee, which you have signed, together with the observance of the information contained in this owner's manual are the essential conditions to give your recent purchase a long life.

Your holiday, your favourite sport, your job, which has from today the name **SELVA MARINE**, will be a further moment of satisfaction.

This manual belongs to Selva joint-stock CO. All rights reserved. Any partial or total reprinting without the permission is prohibited.

INTRODUCTION

Before operating this outboard motor, read this Owner's Manual carefully and completely, pay attention especially to the safety measures and rules.

Your safety and other people's safety do not depend only on your ability at using the motor, but they depend also on your knowledge and on the efficiency of the motor as well as on the respect of the laws and regulations relating to the use of outboard motors.

We suggest you improve your knowledge of the motor so that you can sail with mastery and confidence.

If any kind of repair on the motor should not have been clearly described in this manual or if you want to order spare parts or accessories, or if you have any question about the operation or maintenance of your outboard motor, please consult an authorised **SELVA MARINE** service station or **SELVA MARINE** dealer

ATTENTION

Pay attention to all the particularly important information that in this manual are distinguished in the following ways:



Safety measures and rules, which protect the machine operator and other people from serious accidents or risks.

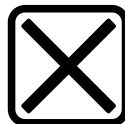

Directions or special precautions that must be taken to avoid damage to the outboard motor or personal accidents.



Directions that make procedures easier or clearer. Technical information.

OUTBOARD MOTOR IDENTIFICATION DATA

This data is stamped on the label attached on the clamp bracket, as shown on the picture 1.

When you receive your new SELVA outboard motor write down the serial number, it will be useful to you in case you will have to order spare parts or for reference if your outboard motor should be stolen.



Make sure that the data on the label is the same as the data written in your registration book.

Picture No.1



Do not install an outboard motor with more horsepower than shown in the certification of your boat.

SERIAL NUMBER RECORD

Write down the identification number and the model of your outboard motor in the spaces below.

MODEL

SERIAL NUMBER

CONTENTS

<u>GENERAL INFORMATION</u>	1
Introduction	2
Outboard identification data	3
Serial number record	3
Directions for use. Basic safety measures	5
Specifications	7
Swivel Bracket model chart	8
Location of main components.....	8
Remote control box.....	9
Control functions.....	9
Wires' colour.....	10
Wiring diagrams	10
Symbols	10
<u>THE USE OF THE OUTBOARD MOTOR</u>	12
Preliminary controls chart	12
Check of the supply	13
Outboard motor mounting.....	13
Motor fixing	14
Trim angle adjusting	14
Remote control box installation.....	15
Steering control device mounting	17
Battery mounting.....	18
Fuel	19
Fuel tank clamping and pipes connection.....	19
Automatic lubrication. M.A.	20
Motor oil re-fill	20
Use of the remote control box.....	21
Starting	22
Verifications before starting the motor	22

Starting procedure.....	22
Verifications when the motor is on	22
Navigation	23
Tilt-up the motor	23
Overheat warning System.....	24
Directional skeg.....	24
Running-in procedure.....	25
Pre-operation checks	25
Stopping procedure.....	26
Emergency stopping procedure	26
Standard stopping procedure.....	26
Restart after a long motionless or oil circuit cleaning	26
Cleaning	27
Cleaning cooling-water passages	27
<u>MAINTENANCE</u>	27
Periodic inspections and adjustment charts.....	28
Greasing chart	29
Greasing and addition	29
Camshaft's oil filling	29
Gearbox-oil change	30
Spark plugs	30
Sacrificial anode.....	31
Replacement of the propeller	31
Towing	31
Storage.....	32
<u>TROUBLESHOOTING</u>	33
Troubleshooting chart	33
<u>EXPLANATORY PICTURES</u>	35

DIRECTIONS FOR USE



BASIC SAFETY MEASURES

To use the outboard motor you must have all the requisites provided by law (physical suitability, insurance, government duties, registration, and so on). We suggest you become familiar with your boat equipped with SELVA motor in places, which are not too crowded.

Taking some medicines, alcoholic drinks or drugs increase considerably the risk of accidents.
Make sure that you are in a physical condition suitable for driving. Pay attention to tiredness.

The engine operator should not let his mind wander, or be distracted or influenced by other people, things or actions,(do not smoke, eat, read, and so on.) while steering the boat.

Use fuels and oils suitable for the engine, which are listed in the "greasing chart".
Check every so often the oil level and the fuel level.

Stop the motor before every kind of maintenance or cleaning procedures, and in case of complicated maintenance take the spark-plug cap out.
Picture No. 2.

Before opening the top cowling, wait till the engine has cooled.
Do not open the top cowling, when the engine is running.

Picture No. 3.

PAY ATTENTION TO THE PROPELLER

The propeller is certainly the least protected part of your motor. It is therefore forbidden to get near the propeller when this is rotating. You must leave bathers, skiers and other boats users enough space to move, in order to avoid any contact with the propeller.

Picture No. 4.

The engine operator must attach the engine stop switch lanyard to his wrist when the motor is on.

Picture No. 5.

Never sit on the motor.

Picture No. 6.

The motor must always have its top cowling on, when it is operating

Picture-No. 7.

When you connect the fuel joint, check the proper connection
For the models with automatic Oil mixer, control the proper connection of the oil joint.

Picture No. 8.

The anti-tilt lever and the Shock Absorber lever must always be engaged while the motor is in motion. (models with Swivel Bracket or Shock Absorber)

Never tilt-up the motor out of the water, while it is in motion.

Picture No. 9.

When starting or operating the engine, do not touch electrical parts and particularly the ignition-coil, the high voltage wire, the spark-plug cap and the spark-plug itself.

When opening the safety valve of the fuel tank, highly flammable vapours come out. Do not smoke, inhale or use open flames close to it.

If the motor has had an accident, you should have it fully checked, before you use it again. If necessary let the **SELVA MARINE** authorised skilled staff have a look at it.

Do not use the motor, if the damage could have compromised the sailing safety.

Any alteration attempted on your motor or the removal of any of its basic elements, can compromise its safety, it is against the law, and it means the immediate loss of your guarantee.

Observe the laws in force.

Pay great attention to the weather conditions. Listen to the weather forecast and take the warnings to the sailors into consideration.

Keep your boat and equipment on board in a perfect state of efficiency.
Keep enough spare parts on board.
Inform somebody of your route, before sailing.

Prevent fires and explosions.

Before operating an outboard motor, you must know the laws and regulations relating to navigation.

Avoid sudden and dangerous manoeuvres

SELVA motors are only meant as propulsion for pleasure craft.

SELVA joint-stock CO. declines all responsibility for any damage to items or harm done to any person, which is due to an improper use of the motor.

SPECIFICATIONS

MODEL	Bull Shark 40xs - I684A	Bull Shark 50 - I684A	Tiger Shark 80 - I1024A
POWER	40HP (29.4 Kw)	50HP (36.7 Kw)	80HP (58.8 Kw)
FULL THROTTLE RANGE	5500	5900	5500
PISTON DISPLACEMENT	684	684	1024
BORE X STROKE	80X68	80X68	80X68
NUMBER OF CYLINDERS	2 in a line	2 in a line	3 in a line
ENGINE TYPE	Cycle eight 2 stroke LPDFI		
FUEL ADMISSION	Direct injection		
AVERAGE CONSUMPTION	6	8	13
FUEL	Unleaded gasoline – R.O.N. minimum 95		
FUEL TANK	Separated. Lt. 23		
MOTOR OIL	NMMA TC-W3 - SAE J 1536 Grade 3		
MOTOR OIL TANK CAPACITY	Lt. 3 ~		
CAMSHAFT OIL	API SE, SF, SG,SH,SJ - SAE 10W-30; 10W-40 ;15W-40		
CAMSHAFT OIL TANK CAPACITY	500 gr.		
IGNITION	T.C.I.		
SPARK LEAD	Computer regulated		
ELECTRIC STARTING	Standard with a generator 12V/ 300 W and current regulator		
SPARK PLUGS	BOSCH: FR 7D+ - CHAMPION: RC9YC - EYQUEM: RFN52LZE		
EXHAUST	Bi-lateral and through propeller hub		
COOLING	Water cooling with forced circulation caused by a pump		
PROPELLER	Ratio 13/27 anti-weed with three blades and silent block incorporated		
GEAR SHIFT LEVER	forward gear - neutral gear - reverse gear		
REC.GEARBOX OIL	API GL-5 - SAE 80W-90		
GEARBOX OIL QUANTITY	480 cc. / 440 gr.		600 cc. / 500 gr.
TRIM ANGLE ADJUSTING	5 positions, which you can select through a pin		
SUSPENSIONS	Silentblock at compression / traction controlled		
RECOMMENDED HEIGHT OF THE TRANSOMS	Long Shaft 508 (20 inches)		
WEIGHT (basic models Kg.)	98		120

Selva joint stock CO reserve the right to change weight, construction, materials and characteristics without warning and without therefore have to change the motors, which were built previously. **See picture N. 10 for the Bull Shark dimensions and picture N. 11 for the Tiger Shark dimensions.**

Swivel Bracket model chart

MODEL	BULL SHARK 40 XS	BULL SHARK 50	TIGER SHARK 80
SWIVEL BRACKET SHOCK ABSORBER	■	■	■
SWIVEL BRACKET POWER TRIM GWO37	■	■	
SWIVEL BRACKET POWER TRIM GWO27			■

LOCATION OF MAIN COMPONENTS Picture No. 12

N°	DESCRIPTION	N°	DESCRIPTION
1	Hood	18	Gearbox oil-drain hole
2	Hood hook back lever	19	Water inlet for speed meter
3	Motor oil tank access manifold	20	Water inlet for cooling
4	Hood hook front lever	21	Anodes
5	Fuel connector	22	Propeller
6	Remote Control Box wires	23	Water inlet to clean the cooling circuits
7	Holes to fix the motor at the transom (Models with Shock Absorber or Power Trim)	24	Motor lift on the left side
8	Wires to connect the battery	25	Indicator tube for the cooling water
9	Gas control cable	26	Motor data label
10	Gear control cable	27	Tim-adjusting pin
11	Plate to connect the steering	28	Anti-tilt hook control lever
12	Trim switch on tray		
13	Support to lift the motor on the right side		
14	Shock Absorber control lever (Models with Shock Absorber)		
15	Directional Skeg		
16	Anticavitation plate		
17	Gearbox oil-level hole		

REMOTE CONTROL BOX

MAIN COMPONENTS

- 1 CONTROL LEVER
- 2 NEUTRAL LEVER FIXING ROD
- 3 NEUTRAL GEAR ACCELERATOR CONTROL LEVER
- 4 STARTING KEY
- 6 SECURITY SWITCH
- 7 TACHOMETER CONNECTOR
- 8 ELECTRIC MOTOR WIRING
- 9 GAS CONTROL FLEXIBLE WIRES
- 10 GEAR CONTROL FLEXIBLE WIRES
- 11 SCREW REGULATING CLUTCH AND ACCELERATOR
- 12 TRIM SWITCH

Picture No. 13

CONTROL FUNCTIONS

(remote control box)

Control lever

It controls the selection of the forward gear, of the reverse gear and of the acceleration

Neutral lever fixing rod

It fixes the control lever in the neutral position end has to be pulled up to select the forward gear or the reverse gear.

Neutral gear accelerator control lever

It allows to control the accelerator when the clutch is in the neutral position, to increase the number of r.p.m. you must pull it up.

Starting key

Turning it in a clockwise direction till the position ON the electric circuit operates, continuing with the rotation till the START position the motor starts. If you release the key from the START position, it returns automatically to the ON position. To switch of the motor put the key in the OFF position.

Security switch

Insert the nippers of the wire to be bound around the pulse. In case of necessity give a blow to the wire and the motor stops.

The motor doesn't start if the nipper of the security switch isn't connected.

Tachometer connector

To be used to connect the tachometer.

Wiring connector

To be engaged with the motor connector to get the electrical connection.

Power Trim switch

Switch to control the motor's inclination.

CONTROL FUNCTIONS

Motor

Hood Hook.

Device to fix the hood. To release it you have to turn the two handles counter clockwise.

Picture No. 14

Fuel connector

Inserting the connector you connect the fuel hose.

Picture No. 15

Trim switches.

(only models with Trim Tilt)

It allows the insertion of the Trim Tilt device directly from the motor.

Picture No. 16

Support to lift the motor

To keep the motor in tilt position, turn the support and place it on the bracket.

Picture No. 17

Shock Absorber control lever

Rising the lever you can tilt the motor.

It has to be lowered before beginning the cruising.

Picture No. 18

Trim adjustment pin.

It can be inserted in the brackets in different positions allowing a correct adjustment of the trim.

Picture No. 19

Directional Skeg

The directional skeg allows to balance the left and right turn efforts. It acts also as an anode to avoid the electrochemical corrosion of the motor.

Picture No. 20

WIRING DIAGRAMS

Wires' colour

G	Green
GL	Green Bleu
GB	Green Black
L	Bleu
O	Orange /
LBI	Light Bleu
R	Red
P	Pink
Gy	Grey
RBI	RedBlue
BLb	BlackLighBlue
PR	PinkRed
W	White
WB	White Black
WG	White Green
WY	White Yellow
Y	Yellow
YG	YellowGreen
YL	Yellow Bleu
YB	Yellow Black
YR	Yellow Red

Electrical wiring diagram

(Picture No. 21)

1. Spark plug
2. Ignition coil cylinder #1
3. Ignition coil cylinder #2
4. Ignition coil cylinder #3
5. Starter solenoid
6. Generator
7. Oil Tank
8. Trim Tilt Switch
9. Trim Tilt Switch (Remote Control Box)
10. Starting Panel
11. Buzzer

12. Emergency cut-off switch

13. Engine temperature Sensor (ETS)

14. Air temperature Sensor (ATS)

15. Throttle position sensor (TPS)

16. PC Connexion

17. Crankshaft sensor

18. Fuel injector cylinder #1

19. Fuel injector cylinder #2

20. Fuel injector cylinder #3

21. Electrical fuel pump

22. Main relay

23. Fuel pump relay

24. Temperature alarm relay

25. Power trim and tilt UP relay

26. Power trim and tilt DOWN relay

27. Fuse 10 A

28. Fuse 20 A

29. Fuse 15 A

30. ECU

31. Neutral switch

32. Trim pump

33. Neutral microswitch

34. Rectifier regulator

35. Battery

36. Motor tachometer

37. Starter motor

38. Fuse 1 A

SYMBOLS

Picture No. 22

Engine

1 - A serious risk is present. The machine operator must read and follow the instructions in the manual.

2 - Outboard motor free lock.

3 - Warning against fire-hazard (fuel tank)

Picture No. 23

Remote control box

1- Reference to control lever position

2- Reference to the starter key position

3- Cut-off switch

THE USE OF THE OUTBOARD MOTOR

PRELIMINARY CONTROLS CHART

DETAIL	CHECK DESCRIPTION	PAGE
Complete supply	Check that the motor supply includes all the components that are in the detailed list.	13
Right installation	Check the proper installation of your motor (the centre of the transom).	13
	Check the proper mounting height of your motor.	13
	Check the tightness of the clamp screws and of the hand levers.	14-15
	Check the proper installation of the remote control box.	15
Battery and fuel tank	Check the position of the battery and fuel tank from detailed list.	18 - 19
Fill up	Check that the fuel, the motor oil and the camshaft oil are conform to the specifications.	7
Fuel hose connection	Check the proper connection of the fuel hose.	19
Oil circuit fill up	Check that the oil pipes are full	20-25-26
Check the equipment on board	Check that you have on board everything necessary to face a possible emergency.	



Before leaving always check your motor to make sure that it is in a perfect state of efficiency, check its proper and safe functionality. Failure to check as shown in the chart could result in severe injury to people or damage to the boat.



If you ever have a question about the operation of your outboard motor, or if you should find any kind of anomaly, please consult a SELVA MARINE dealer. The time which is needed to check your motor is very modest, but the safety, that you obtain from it is enormous

Check the supply.

When you receive your motor check that:

- the packing is not damaged
- the supply corresponds to the detailed list
 - 1 the entire motor
 - 2 the steering rod with nuts
 - 3 fuel tank with the fuel hose and quick reverse connection
 - 4 remote control box
 - 5 nuts kit to fix the motor on the transom
 - 6 Kit to fix the remote control box
 - 7 rope for cut-off switch
 - 8 rope with handle for the emergency starting
 - 9 declaration of conformity E.E.C.
 - 10 certificate of guarantee
 - 11 use and maintenance manual
 - 12 tools kit
- there is no evident damage. If there is a damage or parts are missing, you must inform immediately and in details the forwarding-agent, SELVA joint stock Co. or its area agents.

Picture No.24

Outboard motor mounting.



A good position of the motor on the transom is very important to have an appropriate trim angle and therefore to obtain a good performance from your boat

The motor has to be mounted on the centre line of the stern belt. To have the optimum mounting height of the outboard motor, you must mount it so that the anti-cavitation plate is between the bottom of the boat and a level of 2 cm below it and it is parallel to it.



If the mounting-height is too high, cavitation tends to occur and consequently there will be a falling-off in the performance and a probable overheating of the motor. If the mounting-height is too low, the water-resistance will increase and thereby reduce engine efficiency.



The motor must be vertical to the water surface and the bracket mounted on a flat even surface and should be fully supported by the top edge of the transom. If the bracket is not fully supported or, if the transom height is too low, a hard wood block should be securely fitted between the bracket and the transom.

Picture No. 25

MOTOR FIXING

Model with Swivel Bracket

After having put the motor in the correct position, clamp the screws of the levers. Then make two holes in the transom in correspondence of the holes in the fixing brackets. Apply some dope on the holes made and on the screws to be used to fix the motor (which are with the motor). Insert the screws and the washers so that the nuts are inside the boat. Then clamp very well.

Models with Shock Absorber-Power Trim

After having found the correct fixing place of the motor, make four holes in the transom so that they are in correspondence with the holes in the fixing brackets. Then apply some dope on the holes made and on the bolts (accessories). Insert the bolts from outside of the transom and screw the bolts clamping them very well.

Picture No. 26



Use only bolts, nuts and washers which are in the motor packing. If you need to use other components, be sure that they are of the same quality regarding the material and strength. Tighten the bolts and check the tightening of bolts and levers after running the motor.

For the models with Shock Absorber and Power Trim, the two screws that are in the brackets are used only to keep the motor while fixing it and you have to take them away when you've fixed it.

We suggest you to ask for the help of skilled people to make the operations over described.

TRIM ANGLE ADJUSTING

The trim angle is the inclination angle, that should be given to the motor in order to obtain an optimal performance from your boat.



An improper trim angle does not only affect the performance of your boat, but can also cause loss of control, which means danger for the people on board.



While sailing the motor should be perpendicular to the water surface, but the trim angle can be 3 degrees to 5 degrees.

If the trim angle is made too great, the buoyancy centre of the boat will shift towards the stern. In this condition, and if the stability moment at the bow is large, the boat will tend to "porpoise". If the trim angle is insufficient, the bow may "plough", making the boat unstable.

When the boat is in stable trim it remains parallel to the water.

Trim Adjusting - models with Trim

The trim-angle adjusting is automatically made and regulated through the utilisation of the Trim.

Picture No. 27

Trim-angle adjusting - models with Shock Absorber

Release the Shock Absorber through the control lever. Tilt the motor and keep it in this position through the tilt-supports. Insert the trim-adjusting pin in the position of correct trim. Lower the supports and place the motor in the original position. Fasten the Shock Absorber releasing the control lever.

Picture No. 28

REMOTE CONTROL BOX INSTALLATION



To install the remote control box and the cables we suggest you contact an official dealer SELVA MARINE.
We suggest you contact this dealer also for the control device installation.



An improper installation of a remote control box may cause a sudden and unexpected loss of control, of the boat. In case or doubts about the remote control installation, ask your SELVA MARINE dealer.

Position of the remote control box



Normally the remote control box is supplied to be in positioned on the right.
If you need to have it on the opposite side, ask your dealer.

When positioning the remote control box pay attention that the control lever can be gripped and operated comfortably and without obstacles. Even the cables must be put in order not to have any obstacle on their patch and must not get in the way of the passengers. Be sure that the cables are long enough and that they can't get entangled when the steering-wheel is operating

Picture No. 29



If the cables aren't correctly installed, they can get entangled causing the loss of control of the boat.



Never bind or entangle the cables of the remote control box. They mustn't be bound with a bending ray inferior to 300 mm. (12 feet).



The cables aren't included in the supply of the motor. They must be of the type **C2**.

Picture No. 30

CONTROL CABLES CONNECTION

To make the connection of the control cables you have to use the Kit K44 (included in the supply) made by:

Nr	4	Remote control heads
"	2	Sheath retainer bolts
"	4	Screws TC Phillips M5x20
"	4	Self-locking nuts M5
"	2	Split pins
"	4	Washers Grower M5
"	2	Seeger rings
"	3	Screws TSPTC M6x100
"	3	Washers M6
"	3	Self-locking nuts M6
"	1	Clamp

Side of the remote control box

To connect the control cables to the box you have to follow the following instructions:

- Remove the lower cover (**6**) of the remote control box by unscrewing the two screws.
- Put the control lever (**1**) in neutral position.
- Screw completely the gear to connect the remote control box (**9**) to the threaded extremity of the cables and fix them with the counter-nut, paying attention not to tighten it too much.
- Put the head of the gear-control lever in the pawl of the gear lever (**10**) and insert the retaining ring (**8**).
- Insert the head of the gas-control cable in the pawl of the accelerator lever (**11**) and insert the retaining ring.
- Fix the sheathing of the cables inserting the sheathing-retainer in its housing.
- Screw the lower cover.

Picture No. 31

Remote control box fixing

After having connected the remote control cables, place the box in the determined position and fix it through the accessories (3 screws M6x100 - 3 washers M6 - 3 self-locking nuts M6) included in the Kit K44.

Picture No. 32

Connection from the side of the motor

To connect the control cables to the motor follow the following instructions:

- Put the remote control lever in the neutral position. Lower completely the gas control lever in neutral position
- Insert the cables in the tray, letting them pass through the holes made on the right side of the fuel connector.
- Screw the remote control heads at the end of the two cables.
- Insert the heads in the pawls of the gears and accelerator levers, paying attention not to muddle the cables.
- Fix the sheath of the accelerator control cable putting the sheath retainer in correspondence of the groove of the sheath and screwing it (using the two screws TC Phillips M5x20 and the two self-locking nuts of the Kit K 44) in the holes made in vertical position on the support of the remote control box sheath retainers.
- Fix the heads on the pawls using the split pins
- Make again the same operation for the gears control cable screwing the bolt in correspondence of the holes made horizontally on the support.
- The sheath retainer support must be fixed in two different positions according to the length of the control cables.

Another adjustment can be made unscrewing the remote control box heads. When you've finished the adjustment fix the heads with the counter nuts.

Picture No. 33



At the end of the operations control the correct functioning of the remote control box.

STEERING CONTROL DEVICE MOUNTING

Insert the control cable in the tube brackets union.

Fix one extremity of the longitudinal rod of control of the steering to the steering fixation plate, using the apposite nut, bolt and washer. Then fix the other extremity of the rod to the cable of control through the nut and the washers.

Insert the sheet-retainer **2** in the control cable. Insert the cable in the tube brackets union, then on the cable itself and then the washer **4** and the ring **5**. stop the sheet in the bracket tube screwing the rings **2** and **5** completely (see the positions of the bolts shown in the picture).

- | | | | |
|----------|--------------------|----------|-----------------------|
| 1 | Control cable | 5 | Ring nut |
| 2 | Ring | 6 | Control cable end |
| 3 | Tube bracket union | 7 | Steering link arm kit |
| 4 | Washer | 8 | Steering plate |
| A | Steering plate | | |
| B | Steering arm kit | | |
| C | Control cable end | | |

Picture No.34

BATTERY MOUNTING

Connecting the battery



Before connecting or disconnecting the battery leads turn the switch key in the anti-clockwise direction, to avoid risks of electric shock, fire or explosion.



It is important to install with the battery the battery disconnect switch. (not included)
Mount the battery in a dry, well-ventilated, vibration-free location in the boat.



Recommended battery type:

Minimum rated capacity (20HR/IEC): 12V 70 A.h

Minimum cold cranking (CCA/EN): 430 A at -18°C (-0.4 °F)

Connect the red lead to the **positive terminal (+)** first; then connect the black lead to the **negative terminal (-)**.

- 1 - Red lead
- 2 - Black lead
- 3 - Battery
- 4 - Battery disconnect switch

Picture No. 35

To disconnect the battery, disconnect the black lead first.



It is important to disconnect the battery connection with the battery disconnect switch only when the engine is stopped. The disconnection of the battery when the engine is running can make serious damages to the engine.



Battery electrolytic fluid is dangerous; it contains dilute sulphuric acid and therefore is poisonous and highly caustic
Always follow these preventive measures:

- Avoid bodily contact with electrolytic fluid as it can cause severe burns or permanent eye injury.
- Wear protective eye gear when handling or working near batteries.
- If any battery electrolytic fluid spills onto your skin, flush with water.
- If you should get battery electrolytic fluid in your eyes flush with water for 15 minutes and get immediate medical attention.
- If you should swallow battery electrolytic fluid, drink large quantities of water or milk followed by milk of magnesia, beaten eggs or vegetable oil. Get immediate medical attention.

Batteries also generate explosive hydrogen gas. Therefore avoid operating in areas which are not well-ventilated or near fire, spark, or open flames. **DO NOT SMOKE** when charging or handling batteries.

KEEP BATTERIES AND ELECTROLYTIC FLUID OUT OF REACH OF CHILDREN.

FUEL



Fuel

The fuel used for the propulsion of internal combustion engines is highly flammable and, in certain cases can become explosive.

Refuelling and maintenance operations must be done in a well-ventilated area and with the engine stopped.

Do not smoke while refuelling, keep away from sparks, flames, or other sources of ignition, which could cause fire or explosion.

Do not spill gasoline. If gasoline spills, wipe it immediately with dry rags, before starting the motor .

Do not overfill the fuel tank, because gasoline expands with the heat and the sun radiation.

Tighten the filler cap securely after refuelling.

Do not let gasoline get into your eyes or onto your skin. Avoid swallowing gasoline or inhaling its vapour. Do not pour fuel off using a pipe.

If you should swallow some gasoline, inhale a lot of gasoline vapour, get some gasoline in your eyes, or if any gasoline spills onto your skin, get immediate medical attention.

Keep out from children reach.

Preparation of the fuel



Use only pure fuels, conserved in suitable and clean tanks, that aren't contaminated with water or other materials.

Use only petrol with a octane number higher than 95 N.O. Research and that does not contain alcohol.

Fuel tank clamping and pipes connection

Put the fuel tank horizontally in the hull, anchored to the bottom, in a place where it does not hinder your movements and so that the pipe is long enough to reach the motor.

Then connect the pipe to the fuel joint.

For this operation you have to insert the female fast fuel connector.

Picture No. 36

Now you have to check the full connection, is secure pulling lightly the joint (do not pull grasping the hose).

Picture No. 37

To release it is enough to pull the ring nut of the fast connector.

AUTOMATIC LUBRICATION M.A. (Multipoint Autolube)

The motor is equipped with the automatic lubrication system “Multipoint autolube” that provide the adequate oil quantity on in relation to the motor running speed.

The device is composed by the following parts:

1. Oil pump.
2. Control levers.
3. Delivery oil pipes.
4. Feeding oil pipe.
5. Oil filter on the feeding oil pipe
6. Oil tank

Fig. 38

At motor receiving fill the oil tank with motor oil according to the technical specification indicated in the special section of this manual.



It's necessary to use synthetic based oil in accordance to the specifications indicated in this manual. Before filling the tank it's necessary to verify that the same is perfectly clean and dry from water. The presence of water in the tank may casue serious damages to the engine.

Motor oil refuelling

To refill the oil system please respect the following procedure:

- Turn the access manifold cap in counter clockwise direction till the complete release and leave it on the top cowling..
- To access the oil tank unscrew the refill cap, remove it and place it on the top cowling.
- Pour carefully the oil inside the tank and when the operation is completed close both the manifold and tank caps.

Fig. 39

LOW LEVEL WARNING ALARM

The motor is equipped with an acoustic device to warn you about the low motor oil level.



When the oil low level alarm start working, the buzzer gives out an uninterrupted sound meaning that it is necessary add oil to the tank.



Check that the oil used to re-fill is in line with the given specifications.

USE OF THE REMOTE CONTROL BOX

Leaving from the position **N** of the control lever, to position in forward gear you have to lift the retainer lever and to put the control lever in position **F**.

The insertion of the gear is indicated by a release of the movement. if the lever goes on in its travel, the accelerator begins to operate. At the end of the travel of the lever there is the maximum opening of the throttle valve.

To select the reverse gear you have to put the control lever in position **R**. If, when the gear is selected, the lever goes on in its travel, the acceleration phase begins

N	Neutral position (neutral)
F	Forward gear (forward)
R	Reverse gear (reverse)
a	Travel to select the forward gear
b	Acceleration travel if forward gear is selected
c	Travel to select reverse gear
d	Acceleration travel if reverse gear is selected

Picture No. 40



The travel of the acceleration when the reverse gear is selected is mechanically limited on the motor.
To avoid damages not to force on the control lever.

Accelerating when neutral gear is selected

To open the throttle when the neutral gear is selected (gear lever in N position), you have to use the neutral gear lever and turn it up.

Picture No. 41



Before selecting the gear you always have to put the gas lever at the neutral position, in repose position (completely down).



The gas lever can be actionned only when the control lever is in position **N**. The control lever can be actionned only when the gas neutral control lever is at repose position (completely down).



For the models with Power Trim: on the control lever of the remote control box there is the switch. If you push on the upper part of it the motor will tilt, while if you push on the lower part of it the motor will drop.

Picture No.42



The micro switch 8 prevents the motor from starting when the gear is selected.

STARTING

Verifications before starting the motor



Check that the hood is correctly locked. Check the correct insertion of the fuel connection.
Check the insertion of the cut-off switch.

Picture No. 43



When the fuel tank connector is inserted some vapours of fuel come out. It's highly flammable and its vapours are explosive, and therefore you may not smoke during this operation and you have to stay apart from flames and sparks.

Starting procedure (when the motor is cold)

Loose the safety valve on the fuel tank.

Using the hand-pump fill up the fuel admission pipe with the fuel (When the pump is hard, it means that you've achieved your aim).

Place the control lever in the neutral position.

Turn the starting key till the ON position and wait for 3-5 seconds.

Turn the starting key till the start position, keeping it into this position not more than 5 seconds.

When the motor starts release the key, that will be in position ON



If the motor doesn't start, after several attempts look at the troubleshooting table.

Picture No. 44

Verifications when the motor is on

Just after starting the motor, you should make sure that:



-after 5/10 seconds some water runs out from the cooling-water pilot holes. The indicator, placed at the entrance of the circuit, provides only for the proper operation of the pump and not for the circulation of water in the head and in the cylinder.

That means that possible shortages will not be indicated. If water does not flow from the pilot-holes, check to see if the water inlets are blocked.

Picture No. 45

- that you do not hear any strange noise
- that the control members work correctly
- the security devices are efficient.

CRUISING

Responsibility during the navigation.

The operator is responsible for the proper running of the boat and for the safety of the people on board.

Everybody must read this manual before cruising. Show all the passengers the location of the safety equipment and the way to use it. Teach one of your passengers, how to pilot the boating an emergency. Familiarise yourself with the laws and regulations in force where you want to sail.

Tilt-up the motor (model with Shock Absorber)

Release the Shock Absorber using the control lever.

Tilt-up the motor and secure it through the motor-lift supports.

To bring it back to the original position you have to lift lightly the motor, lower the motor's supports and bring it till the original position.

Fix the motor using the control lever.

Picture No. 46

Tilt-up the motor (model with Power Trim)

You tilt up the motor using the Power Trim device



If you want to keep the motor in tilted position for a long period you have to secure it using the motor's supports.

They must always be fixed before the Power Trim device operates.

Picture No. 47

If the battery is discharged or there is a failure in the electrical system of the Power Trim, it's however possible to tilt the motor up following the following instructions:

Turn clockwise the trim release screw, that you can reach through the hole on the left bracket.

Lift the motor by hand and fix it in this position pushing towards the high the motor's supports and turning the trim release screw in counter clockwise direction at the end of its stroke.

Lower it and accompany it while lowering it and secure it in this position turning the trim release screw in counter clockwise direction.

Picture No. 48

Trim adjusting (with Power-Trim device unusable)



To adjust the trim when the Trim device is not operating, follow these instructions.

If the motor is in tilt position (lifted) you have to:

- Insert the trim-pin in that position that allows a correct trim.
- Turn in a clockwise direction the trim release screw. (in this way the pressure on the piston of the tilt will discharge and the motor is no more supported) It must be accompanied till it's lowered.
- When the motor leans on the adjustment pin you have to turn the trim release screw in a counter clockwise direction till the end of the stroke, paying attention not to force too much.
- The motor is fixed in the correct trim position and it's possible to cruise.

Picture No. 49

If the motor is in cruising position you need to follow the same operations turning it over by hand.



These operations must be made when the motor is off. If the motor is in tilt position, it begins to lower as soon as you turn the release screw in a clockwise direction.

Overheat warning system



The engine is provided with an overheat warning device. Before the engine becomes too hot, the engine speed is reduced to 3000 RPM by the E.C.U.

If the overheat warning system operates, proceed as follows: Check that water runs out of the pilot hole. If OK, keep the engine at low speed for about five minutes. Then avoid overloading the engine. If no water or just a little runs out from the pilot hole, stop the engine, tilt it up, as shown in this manual and check the water inlets for blockages. If blocked, you must clean them, bring the motor back to the home position and start it and run it at low speed for about five minutes; check that water runs out of the pilot hole.

If after having done all this, you start the engine and no water runs out of the pilot hole, stop immediately the motor and contact a **SELVA MARINE** dealer.



In case of over heating problem, the buzzer gives out an uninterrupted.



Always switch the motor off before tilting it up. Before beginning the cruising again, check that the motor is fixed in the correct trim position.



Never keep the motor on if no water runs out of the pilot hole.

Directional skeg

The directional skeg allows to balance the turn effort.

When the boat tends to turn right, turn the directional skeg right (direction A in the picture)

And if the boat tends to turn left, turn the skeg left (direction B in the picture)



The directional skeg is also an anode to avoid the electrochemical corrosion of the motor. Not to compromise this function you never have to paint it and it must be properly connected to the motor ground.

After the installation or the replacement of the skin you always have to make some verifications of its correct operating.

An improper adjustment of the directional skeg might cause control difficulties and a loss of control of the boat.

Picture No. 50

BREAKING IN (RUNNING-IN) PROCEDURE

Your new engine requires a period of break-in (running-in) to allow mating surfaces of moving parts to wear-in evenly.

Correct break-in (running-in) will help ensure proper performance and longer engine life.

Failure to follow the break-in (running-in) procedure may result in reduced engine life or even severe engine damage.



Do not use pre-mixed fuel in this engine as it may cause carbon deposits on the fuel injector thereby causing engine trouble.

Follow the instructions for breaking-in / running-in carefully.

NOTE:

Break-in (running-in) time: 10 hours

Run the engine under load (in gear with a propeller installed) as follows.

1) First 10 minutes:

Run the engine at the lowest possible-speed. A fast idle in neutral is best.

2) Next 50 minutes:

Do not exceed half throttle (approximately 3,000 r/min). Vary engine speed occasionally. If you have an easy-planing boat, accelerate at full throttle onto plane, then immediately reduce the throttle to 3,000 r/min or less.

3) Second hour:

Accelerate at full throttle onto plane, then reduce engine speed to three quarter throttle (approximately 4,000 r/min). Vary engine speed occasionally.

Run at full throttle for one minute, then allow about 10 minutes of operation at three-quarter throttle or less to let the engine cool.

4) Third through tenth hours:

Avoid operating at full throttle for more than 5 minutes at a time. Let the engine cool between full-throttle runs.
Vary engine speed occasionally.

5) After the first 10 hours:

Operate the engine normally.

PRE-OPERATION CHECKS

If any item in the pre-operation check is not working properly, have it inspected and repaired before operating the outboard motor.

Otherwise, an accident could occur.



**Do not start the engine out of water.
Overheating and serious engine damage can occur.**



**Verify that the oil pipes are full.
In case of air presence in the oil pipes, stop immediately the engine and consult your Selva dealer.**

STOPPING PROCEDURE

Emergency stopping procedures.



In an emergency you can stop your motor by pulling the engine stop switch lanyard.



To start the motor again you have to install again the lanyard's lock plate on the engine stop switch.

Picture No. 51

Stopping in normal conditions

Place the control lever (remote control box) in the neutral position " N ".
Turn the switch key till the **OFF** position.

Picture No. 52

RESTART AFTER A LONG STOP PERIOD OR AFTER EMPTING THE LUBRICATION CIRCUIT

After a long stop period or after emptying the lubrication circuit, it's necessary to fill up the oil lines removing manually any eventual presence of air in the circuit that may casue serious damage to the engine.



Before opering the motor check that the oil delivery pipes are full.



If you don't care about this procedure, it could be dangerous for the motor and compromise its functionality.

CLEANING

Cleaning outside

SELVA motors don't need much cleaning; to clean the painted parts use a cloth soaked with water



Do not use flammable solvents.

Cleaning cooling-water passages

Every now and then after using, clean the cooling-water passages, in order to remove mud and salt, so that they do not affect the performance of your motor.

You can carry out this cleaning operation in two different ways:

1 - Immerse the outboard motor without the propeller in a tank filled up with fresh-water, make sure that the water level is over the height of the water inlets, so that no irreparable damage could be caused to the motor. Shift the gear-shift lever into neutral " N ". Start the engine and run at low speed for a few minutes.

2 - Connect a pipe of fresh-water to the hole for the engine cleaning joint plug (use the proper joint available in the fittings series). Stop the water inlets. Shift the gear-shift lever into neutral. Start the engine and run at low speed for a few minutes.



While cleaning the cooling water passages make sure that water always circulates in the passages, checking its running out of the pilot hole.

Picture No. 53

MAINTENANCE

Before doing any kind of maintenance or check operation, switch off the engine and wait till it has cooled down, then remove the spark plug cap, in order to avoid an accidental starting.

Pay attention to the motor parts, which are still hot, so that you do not burn yourself.

Some maintenance operations must be carried out by qualified staff. Contact **SELVA MARINE** after-sale service.

The following chart lists the periodic maintenance operations to do on your motor.



The pointed out operations must be done by qualified staff.

PERIODIC INSPECTIONS AND ADJUSTMENTS (Running hours)					
OPERATIONS TO PERFORM	INITIAL			THERE AFTER EVERY	
	10	50	100	100	Out of season
Inspection of the conditions of the fuel hoses. If necessary replace them.	■		■	■	■
Check the fuel hose joints for leaks If necessary replace them.	■		■	■	■
Check the proper working of the fuel filters	■	■	■	■	
Replacement of fuel filters					■
Check the proper working of the electrical fuel pump	■		■	■	■
Check the presence of oil in the delivery pipes and verify its consumption.	■	■	■	■	■
Check the motor oil filter functionality.	■	■	■	■	
Motor oil filter replacement.					■
Check and if necessary clean the motor oil tank.				■	■
Check and clean the camshaft's oil tank.				■	■
Check and if necessary clean the vapor separator body					■
Check, clean and adjust the spark-plugs. If necessary replace them.	■		■	■	■

PERIODIC INSPECTIONS AND ADJUSTMENTS (Running hours)					
OPERATIONS TO PERFORM	INITIAL			THERE AFTER EVERY	
	10	50	100	100	Out of season
Check the ignition system	■	■	■	■	■
Check the head screws and the adjustment to the correct torque.	■	■	■	■	■
Check the efficiency of the water pump and of the cooling system	■	■	■	■	■
Replacement of impeller					■
Check the gearbox-oil level	■	■		■	
Check the wear of the anode. If necessary replace it.	■	■	■	■	■
Check the trasmission belt. If necessary replace it	■				■
Check the condition of the propeller. If necessary replace it.	■	■	■	■	■

GREASING CHART			
GREASE POINTS	GREASE THAT MUST BE USED	GREASING FREQUENCY	
		FRESH-WATER	SALT WATER
Gearbox	API GL-5 SAE 80 W 90 MIL -L 2105 C	Check the level after the first 10 running hours. Afterwards every 50 hours. If necessary add till the marked point. Change the gearbox-oil after the first 20 running hours and afterwards every 100 running hours; and anyway each season.	
Camshaft	API SE, SF, SG, SH SAE 10W-30 10W-40 15W-40	Check the oil level every 6 months. If necessary add till the marked point. Change the oil after the first 10 running hours; afterwards every 100 hours, anyway change the oil once per season.	
Bushes of the clamps pipe	SPRAY LUBRICANT	60 days	30 days
Cowling lock levers pins	SPRAY LUBRICANT	60 days	30 days
Tie rod carburettor levers	WATER- REPELLENT MARINE GREASE	60 days	30 days
Propeller shaft	WATER- REPELLENT MARINE GREASE	60 days	30 days
Clamp screws	WATER- REPELLENT MARINE GREASE	60 days	30 days
Gear-shift lever	SPRAY LUBRICANT	60 days	30 days

Greasing and additions

The part, which must be filled with oil, are the camshaft oil tank and the gearbox.

Camshaft oil filling



When delivered, the camshaft's oil tank is empty, before operating the engine fill it with oil.



The oil must agree with the characteristics listed in the greasing chart, and must comply with the quantity pointed out in the technical detailed list.

Camshaft oil change

To change the camshaft's oil do as follow:

Keep the motor in vertical position.

Remove the plastic coner around the shaft of the engine

Place a container to collect the used oil under the drain-oil hole

Take out the oil-level plug and the oil drain-plug.

Wait until the oil has drained completely, (during this operation you must check, if water or other foreign bodies are to be found in the drained oil. They are signs of anomalies which must be identified and repaired by qualified staff, before using the motor again).

Insert the oil drain plug and check the seal.

Throught the filling hole fill the oil.

Insert and tighten the oil-level plug.



The used oil must be given to the proper collecting centres or to a SELVA service point.

Picture No. 54

Gearbox-oil change

Selva supply the motor already with the oil, which the user will have to change completely after the first 20 cruising hours
After this change you must check its level every 50 hours and change it every 100 hours, and anyway each season

To change the oil do as follows :

Keep the motor in vertical position.

Place a container to collect the used oil under the gearbox.

Take out the oil-level plug and the oil drain-plug.



They have a different size and after the oil change they must be replaced in their proper seat.

Wait until the oil has drained completely, (during this operation you must check, if water or other foreign bodies are to be found in the drained oil. They are signs of anomalies which must be identified and repaired by qualified staff, before using the motor again).
Inject the oil into the oil drain-plug hole.



The oil must agree with the characteristics listed in the greasing chart, and must comply with the quantity pointed out in the technical detailed list.

Insert and tighten the oil-level plug and the oil drain plug.

Picture No. 55



The used oil must be given to the proper collecting centres or to a SELVA service point.

Spark-plugs

The spark-plug must be often inspected because heat and deposits affect its efficiency so that the performance of the motor will be affected too.

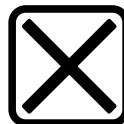

The inspection of the spark-plug must be done when the engine is not running and it has cooled down.

It is very important to check, that the part made of porcelain is not damaged because this could allow external sparks, which could lead to explosion or fire.

To remove the spark-plug use the supplied spanner; using an abrasive brush, remove any depots, then check the wear condition and the spark-plug gap (the gap must be 0,6 mm, to measure it use a thickness gauge)

If the spark-plug is badly worn you must replace it with a new one which must agree with the characteristics listed in the specifications chart.



The spark-plug torque is 20 Nm (~ 2. kgm). If a torque-wrench is not available, you can obtain a good estimate of the correct torque turning the spark-plug completely by hand and then turning it with the spanner, a new spark-plug must be turned ~ 90° and an old one 15° ÷ 20°.

Replace the spark-plug cap, checking that it is correctly fitted and then replace the top cowling.

Picture No.56

Sacrificial anode.

To protect the motor against electrochemical corrosion, due to the presence in its structure of many different materials, a sacrificial anode has been applied.

The anode will be subject to a strong corrosion, so you have to remove the scales from the surfaces of the anode periodically.



Failure to clean it, will affect its effectiveness.



Do not paint the anode, for this would render it ineffective.

When the corrosion compromise its functionality, you have to replace it.

Picture No. 57

Replacement of the Propeller

The propeller is one of the components, which have a great influence upon the performance of the motor. An unsuitable or damaged propeller can cause serious damages to the motor besides reduce the performance.

For an careful choice of the propeller consult a **SELVA MARINE** service centre.

Remove and replace the propeller do as follows:

- wait until the motor has cooled down and remove the top cowling;
- remove the spark-plug cap, to avoid an accidental start;
- protect your hands using strong gloves and insert a wooden lump between the propeller blades and the anti-cavitation plate, to keep the propeller still.
- remove the split pin, the blocking nut, the washer, the propeller and the propeller shoulder.
- spread the propeller shaft with water-repellent grease;
- assemble everything in the opposite direction paying attention to clamp the nut until you reach the position that allows the insertion of the split pin in the hole made in the propeller shaft.
- insert the split pin and fix it widening the end.

Picture No.58



Before making the maintenance operations on the motor, take away the spark plug caps to avoid accidental starting.

Towing

The motor should be towed in the normal running position. Avoid towing with the tilt-support lever only, but use a motor support device.

Storage



To help the endurance of your motor, you must carry out properly the following storage operations:

- Clean the motor and the cooling-water passages.
- Remove the fuel-line connections from the motor.
- Change the fuel filter.
- Empty the float chamber of vapour separator tank.
- Remove the spark-plug and put engine-oil into the hole; turn the flywheel by hand to distribute the oil in the cylinder; replace the spark-plug.
- Check the motor oil tank and if necessary clean it.
- Change the motor-oil filter.
- Change the camshaft oil, check the camshaft's oil tank and if necessary clean it.
- Change the gearbox-oil.
- Check the screws torque.
- Grease all the components as shown in the greasing chart.
- Inspect the anode.
- Store the motor in vertical position, in a dry and not too cold place.



The operations of storage must be done by qualified staff.

Fuel tank.

Store the fuel tank in a well-ventilated place, not in direct sunlight.



For a long period of storage, drain the fuel from the tank

Battery

Disconnect both battery leads from the battery, disconnecting the black lead from the negative terminal first.

Store the battery on a level surface in a dry, cool, well-ventilated, out of direct sunshine.



Follow the battery manufacturer's instructions.

TROUBLESHOOTING



A regular maintenance can help you prevent many problems with your outboard motor.

The following chart lists some common difficulties and their possible causes.



If you still have difficulties, after investigating these, please contact your **SELVA MARINE** dealer.

- A - The engine will not start.
- B - The engine runs irregularly or stalls.
- C - The engine idles unevenly.
- D - Engine speed will not increase.
- E - The engine is overheating.
- F - Engine speed is higher than normal.
- G - Engine speed is lower than normal.
- H - Boat speed is too low.
- I - The boat will suddenly slow.
- L - The starter-motor does not operate

A	B	C	D	E	F	G	H	I	Possible cause
■	■							■	Fuel tank is empty
■	■		■						Fuel hose is incorrectly connected
■	■	■	■			■			Fuel hose is flattened or kinked
■	■	■	■					■	Fuel pump is malfunctioning
■	■	■	■			■		■	Fuel filter is clogged
	■	■		■		■			Improper motor oil
	■	■	■	■		■			Improper petrol
■	■	■	■			■			Injection system doesn't work properly
■									Incorrect starting procedure
■	■	■	■			■		■	Sparks -plugs are fouled.
■	■	■		■		■			Improper spark-plugs
	■	■				■			Incorrect spark-plug gap.
■									Spark-plug cap incorrectly fitted

A	B	C	D	E	F	G	H	I	Possible cause
■									Electric circuit is defective
■	■	■	■			■		■	Ignition-coil is defective
				■		■		■	Clogged water passages
				■		■		■	Faulty water-pump
	■			■		■		■	Thermostat faulty
					■		■	■	Cavitation is occurring
					■		■	■	Propeller is damaged
			■	■	■	■	■		Propeller has not the proper dimensions
			■	■	■		■		Incorrect trim-angle
			■	■			■		Load on boat is improperly distributed
					■				Transom is too high
			■						Transom is too low

A	B	C	D	E	F	G	H	I	L	Possible cause
■									■	Starter-motor is defective
■									■	Starting board is defective
■										Defective electrical connectors
■									■	Battery is undercharged

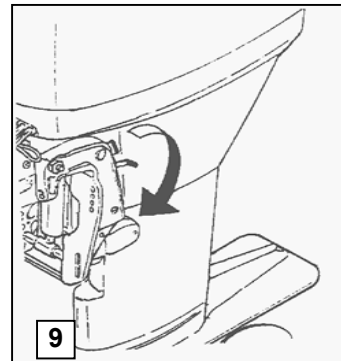
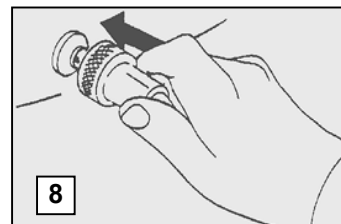
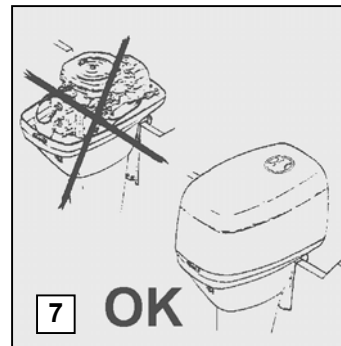
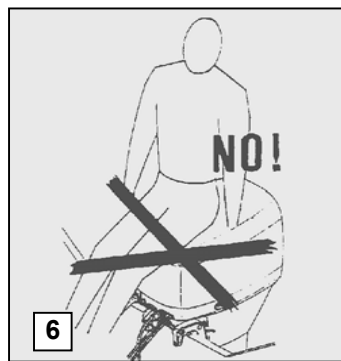
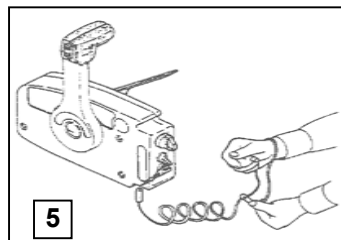
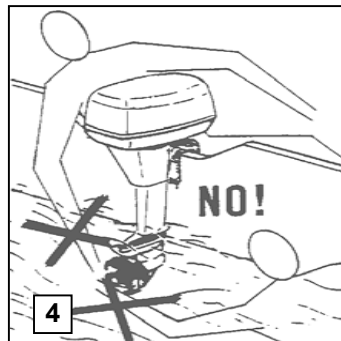
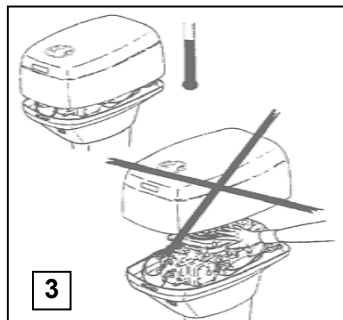
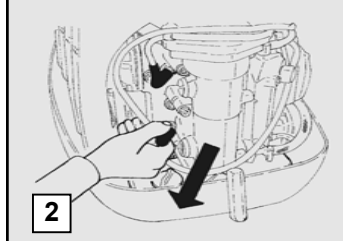
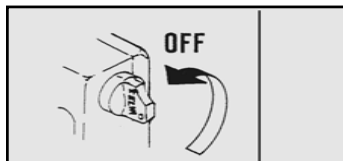
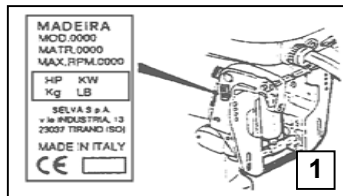

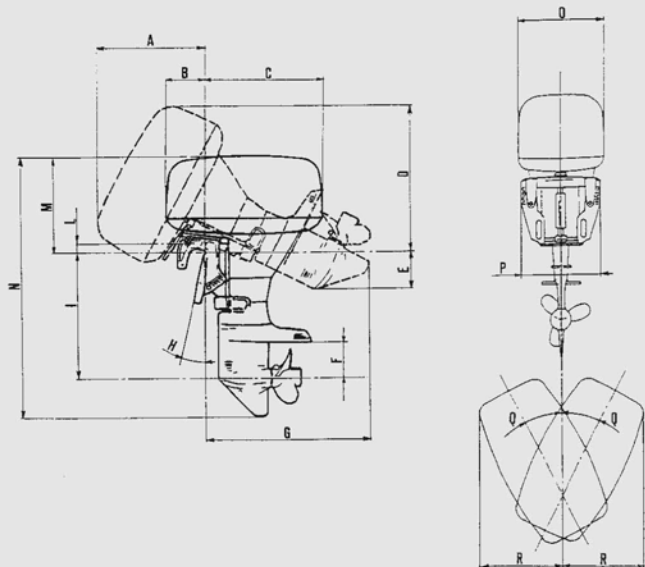

	A	B	C	D	E	F	G	H	I	L	M	N	O	P	Q	R
Bull shark 40xs	480	195	575	745	137	170	920	12°	680	30	520	1385	410	360	26°	315
Bull shark 50	480	195	575	745	137	170	920	12°	680	30	520	1385	410	360	26°	315

10

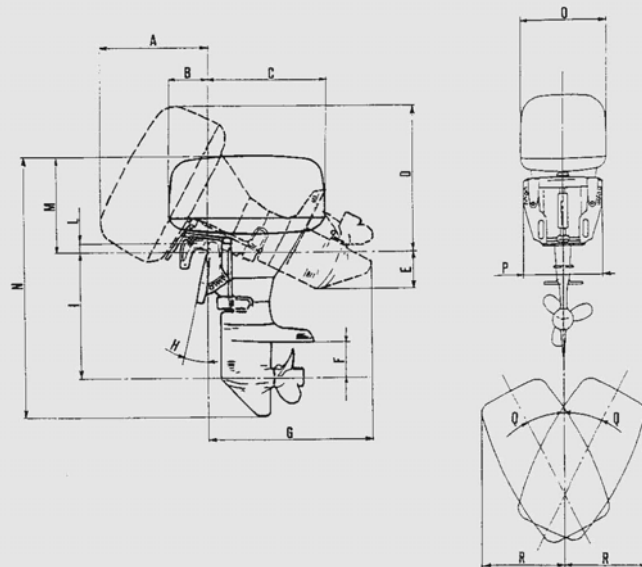

	A	B	C	D	E	F	G	H	I	L	M	N	O	P	Q	R
Tiger Shark 80	550	195	575	770	185	190	945	12°	710	30	595	1485	410	360	26°	315

11

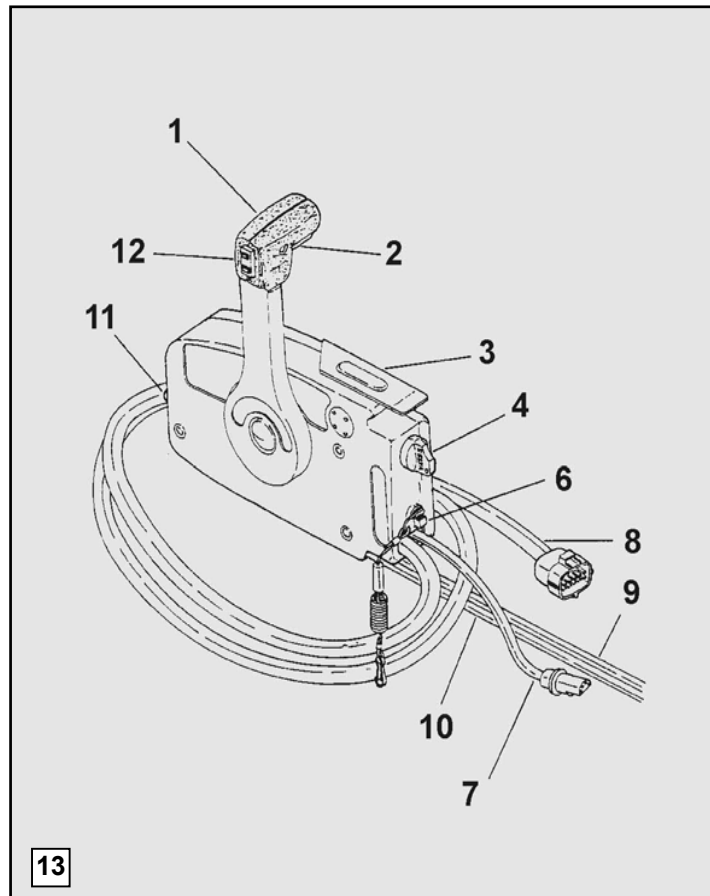
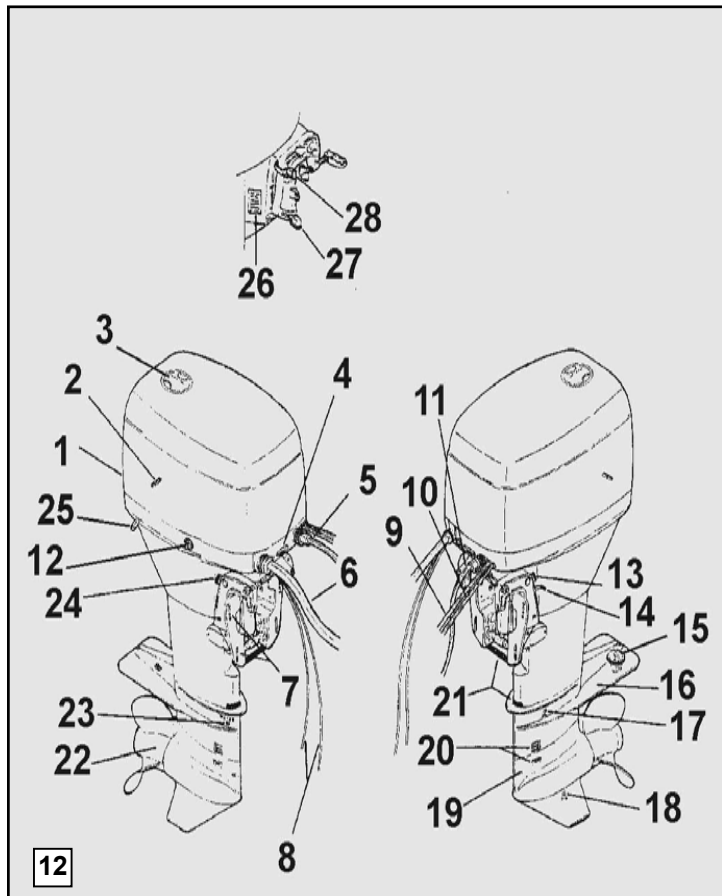

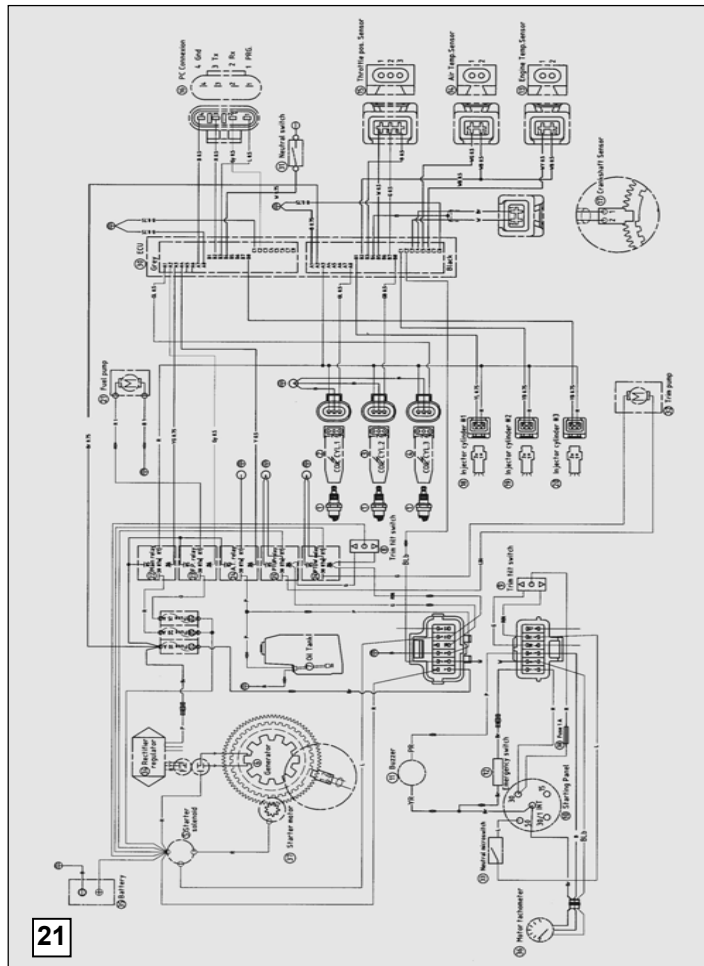
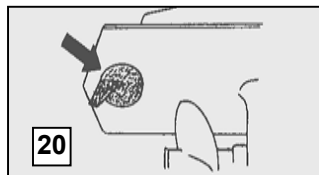
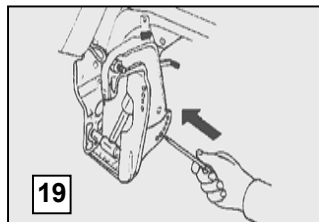
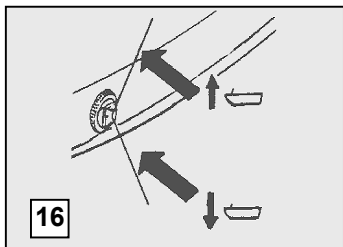
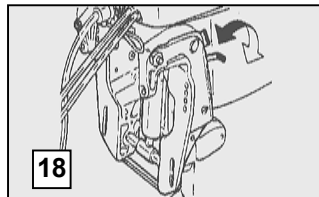
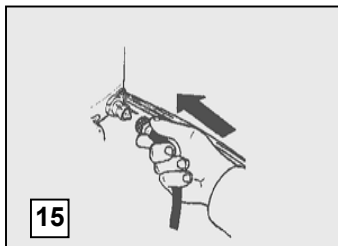
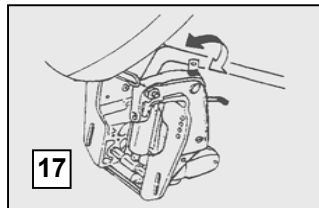
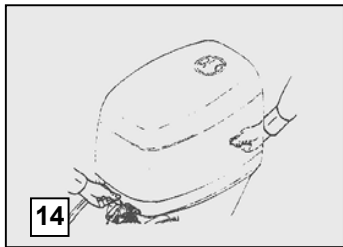

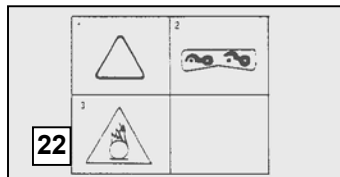

22

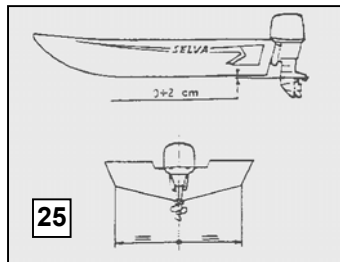

25

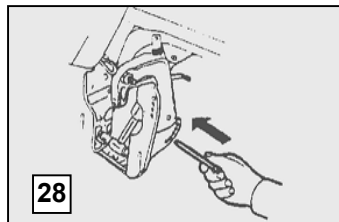

28

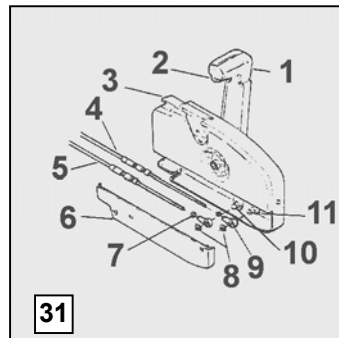

31

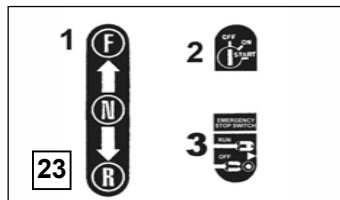

23

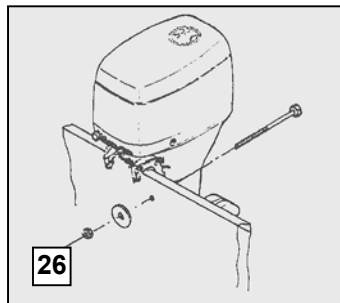

26

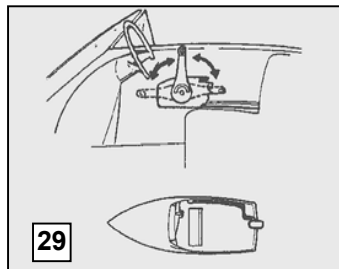

29

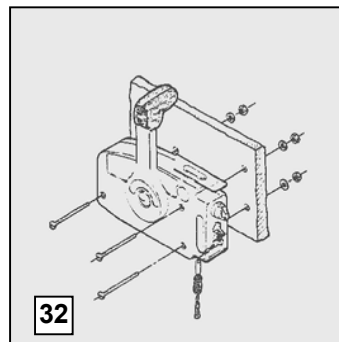

32

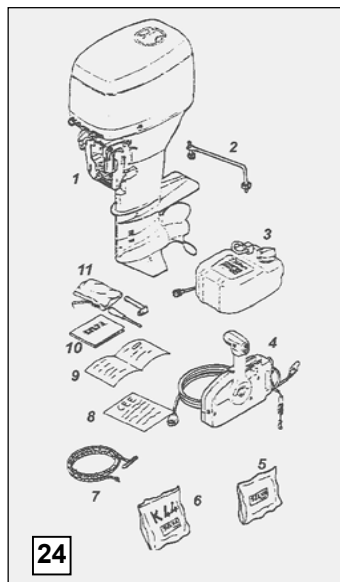

24

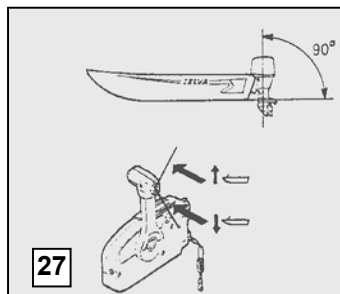

27

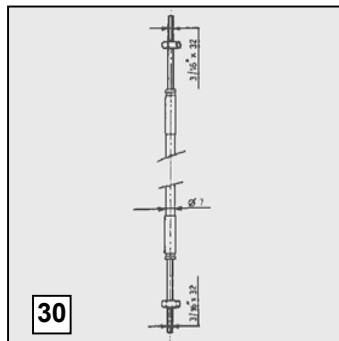

30

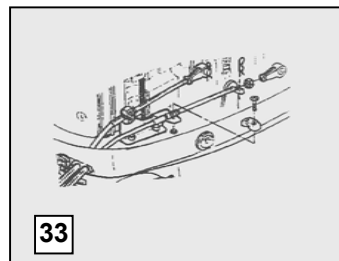

33

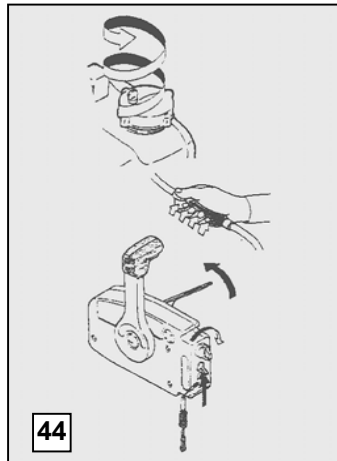
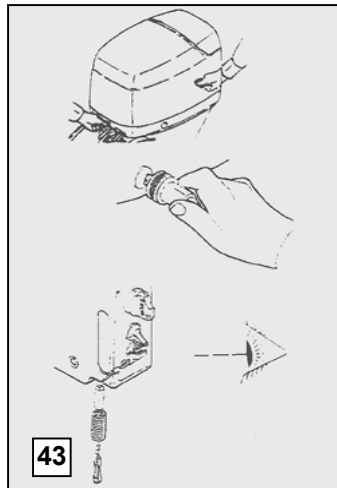
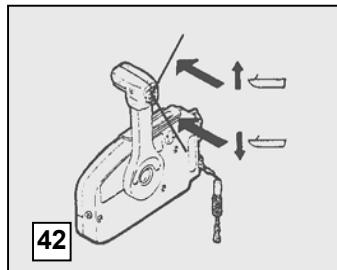
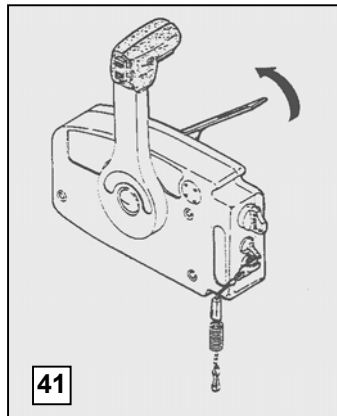
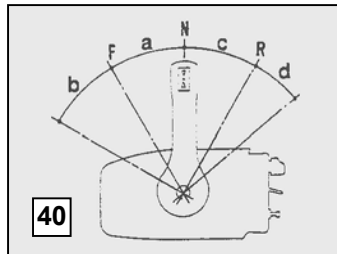
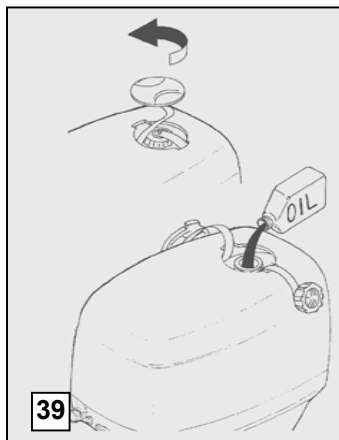
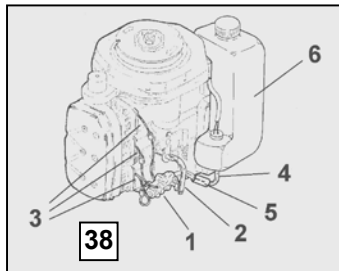
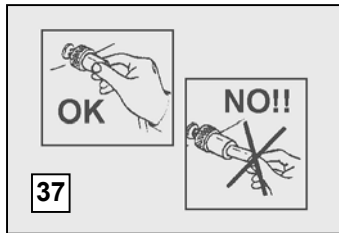
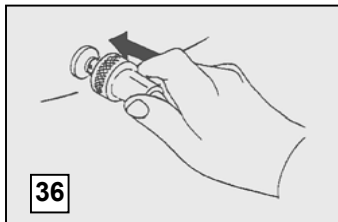
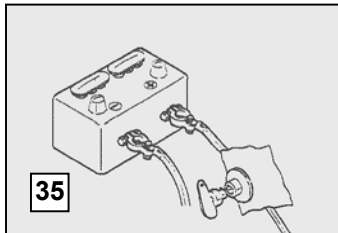
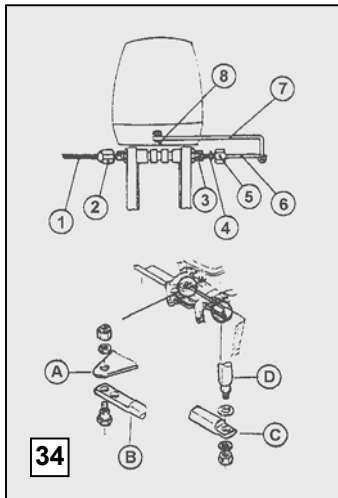

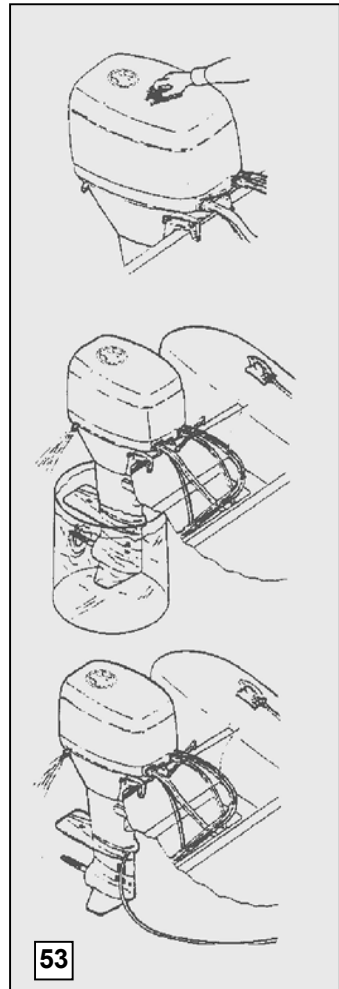
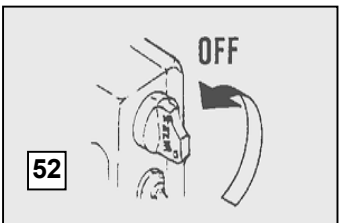
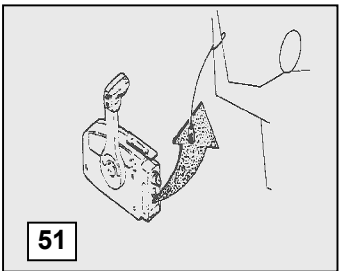
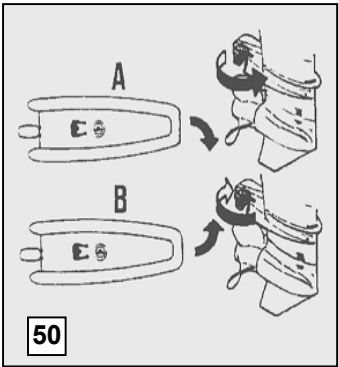
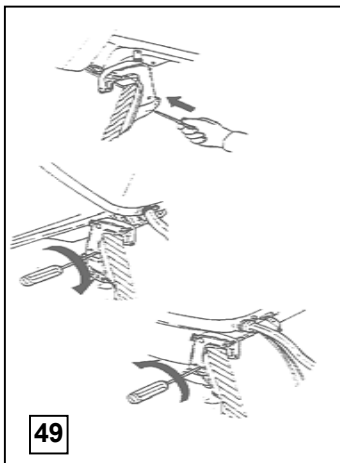
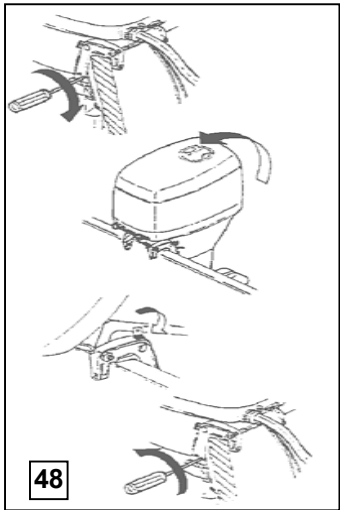
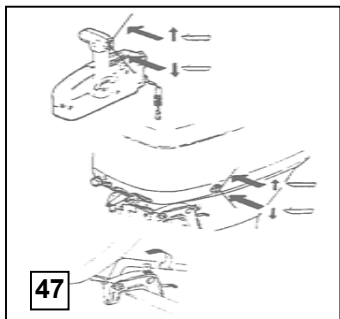
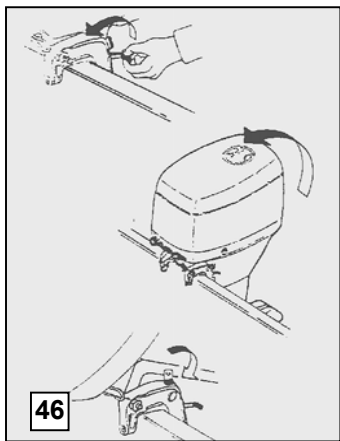
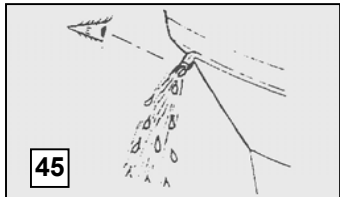

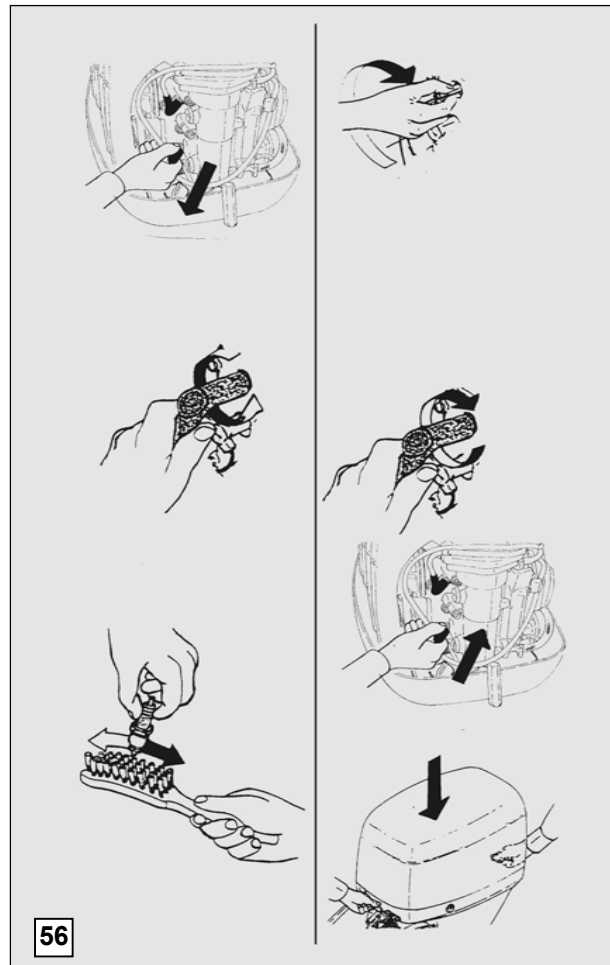
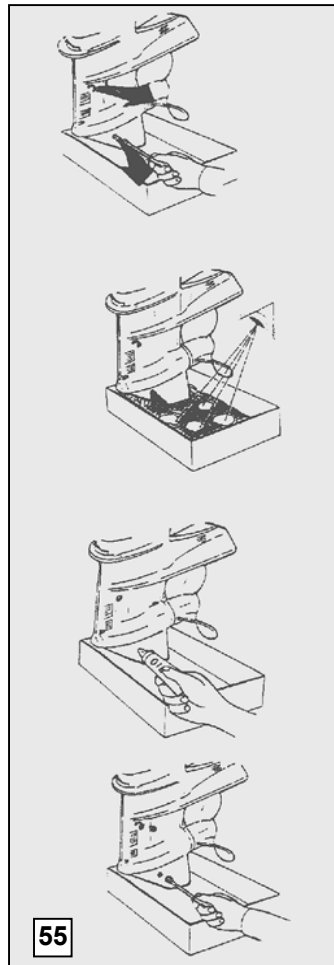
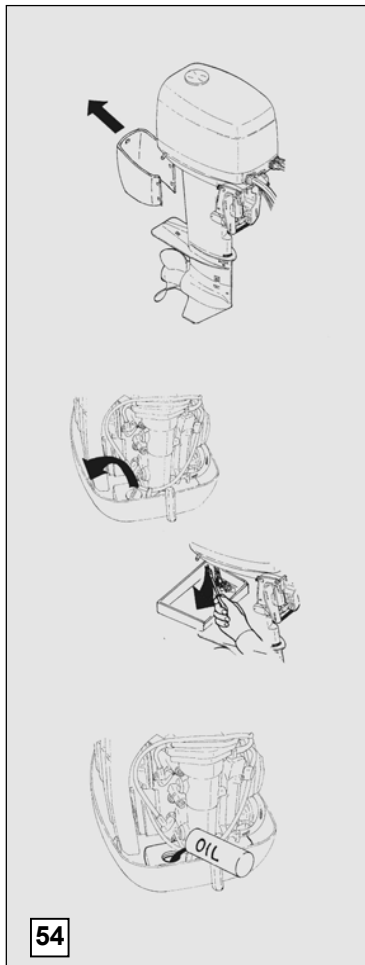

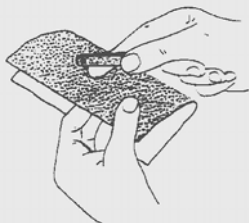
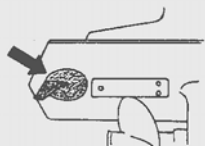
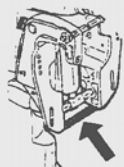

57

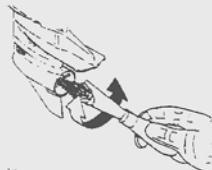

58